

This document is the property of Nian-Yeong Corporation and is delivered on the express condition that it is not to be disclosed, reproduced or used, in whole or in part, for manufacture or sale by anyone other than Nian-Yeong Corporation without its prior consent, and that no right is granted to disclose or to use any information in this document.

CUSTOMER DRAWING

REV.	DESCRIPTION	APPROVED BY	DATE	ECN NO.
B	RELEASE	Emily Suen	29/05/12'	
C	CHANGE P/N及物料	Fido Weng	28/11/13'	
D	變更端子		13/05/14'	

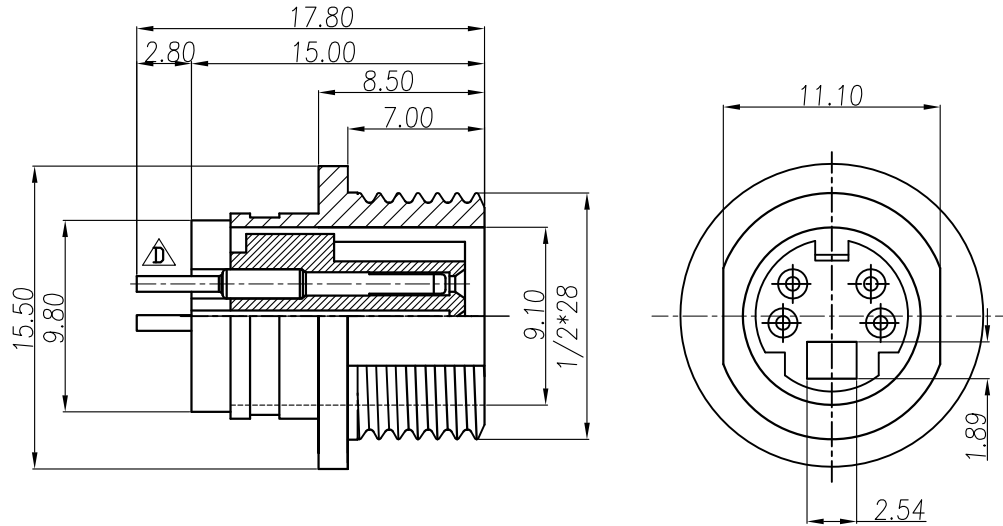

- MATERIAL :
 - 1-1. HOUSING : PBT+30%GF UL94V-0 ; COLOR : BLACK
 - 1-2. CONTACT : PHOSPHOR BRONZE
 - 1-3. NUT : BRASS
 - 1-4. SPACER : STAINLESS STEEL.
 - 1-5. SHELL : BRASS.
- FINISH :
 - 2-1. CONTACT : GOLD FLASH PLATED.
 - 2-2. NUT : SEE TABLE A
 - 2-3. SPACER : SEE TABLE A
 - 2-4. SHELL : SEE TABLE A
- ELECTRICAL SPECIFICATION :
 - 3-1. Rated current : 2A
 - 3-2. Rated voltage : 12V
- Environmental :
 - 4-1. Operation Temperature : -20°C~85°C

TABLE A

MD-04F2-08	鍍/Ni
MD-04F2-02	表金 /GOLD FLASH
P/N	PLATING

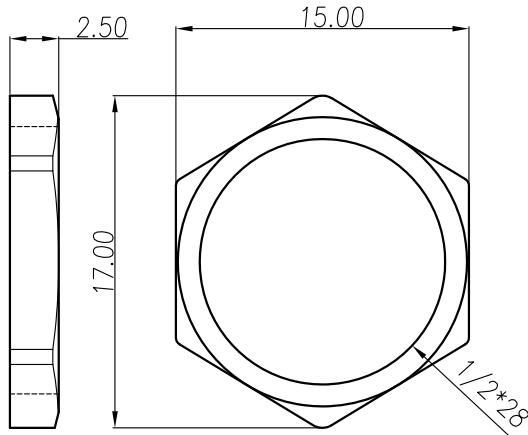

NUT

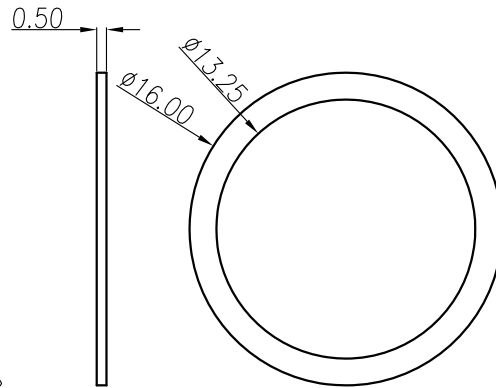

SPACER

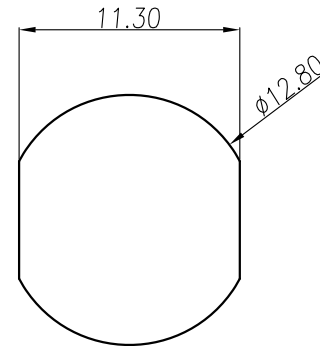

RECOMMEND PANEL CUT-OUT

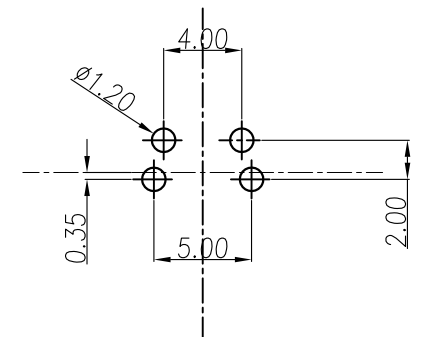

RECOMMEND P.C.B

DRAWN	Angus Lai	APP'D	Fido Weng	UNIT	mm	TOLERANCE		TITLE	MiniDin 4(F) 板端十六角螺母			SHEET	
CHK'D	Emily Suen			SCALE	1:1	.x ±0.10 .xx ±0.05 .xxx ±0.03 .xxxx ±0.01 ANGULA ±1°		PART NO.	SEE TABLE A	DWG NO.	QC2200	VERSION	

NIAN YEONG ENTERPRISE
年永實業有限公司