

This document is the property of Nian-Yeong Corporation and is delivered on the express condition that it is not to be disclosed, reproduced or used, in whole or in part, for manufacture or sale by anyone other than Nian-Yeong Corporation without its prior consent, and that no right is granted to disclose or to use any information in this document.

# CUSTOMER DRAWING

REV.	DESCRIPTION	APPL. BY	DATE	ECN NO.
A	Release	Fideo Wang	27/03/09*	ECN09051
B	Change DIM.	Emily Suen	14/09/11*	
C	增加打點	Emily Suen	02/05/12*	ECN12007
D	尺寸改變	Emily Suen	14/02/17*	ECN17001

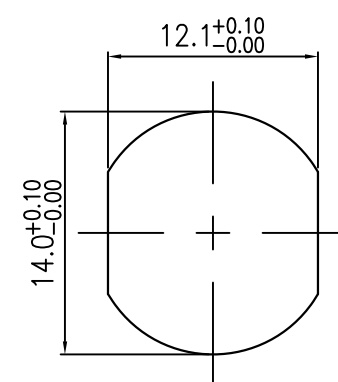
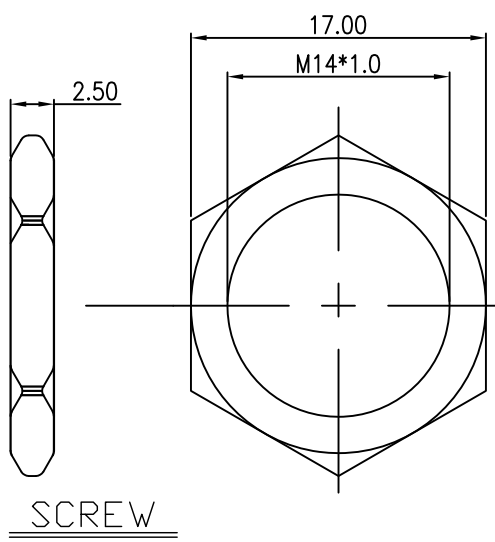
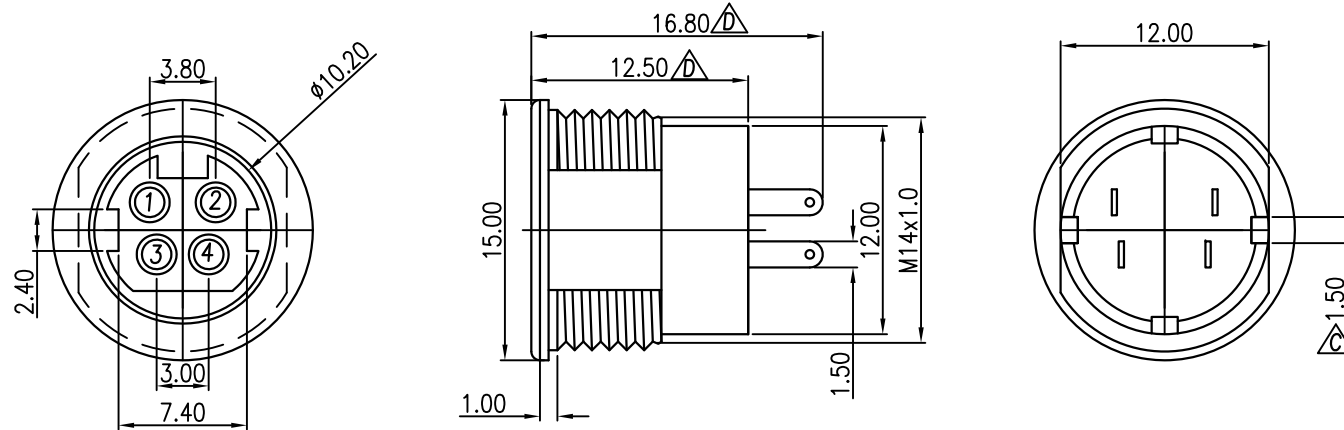

RECOMMEND PANEL CUT-OUT

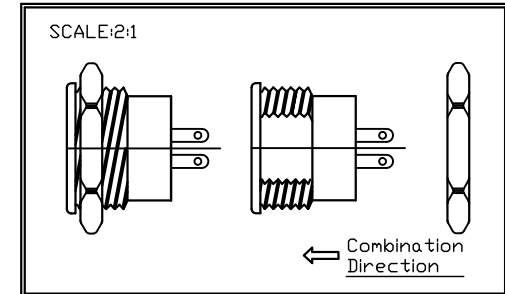

- MATERIAL :
  - HOUSING : PBT UL94V-0 ; COLOR : BLACK
  - CONTACT : PHOSPHOR BRONZE
  - SHELL : BRASS
  - SCREW : BRASS
- FINISH :
  - CONTACT : TIN PLATING OVER NICKEL
  - SHELL : NICKEL PLATED 60u" ~ 100u" OVER ALL
  - SCREW : NICKEL PLATED 60u" ~ 100u" OVER ALL
- ELECTRICAL SPECIFICATION :
  - RATED CURRENT : 7.5A/DC MAX
  - RATED VOLTAGE : 25V/DC MAX
- ENVIRONMENTAL :
  - OPERATION TEMPERATURE : -20 °C ~ 85°C

DRAW	KU	APPVL	Emily Suen	UNIT	mm	TOLERANCE		<b>NIAN YEONG ENTERPRISE</b> 年永實業有限公司	TITLE	POWER DIN 4P 每邊拆開			SHEET
CHECK	Emily Suen			SCALE	1:1	.x ±0.20 .xx ±0.10 .xxx ±0.05 .xxxx ±0.01 ANGULA ±1°			PART NO.	PD-04F2-04	DWG NO.	QC1734	VERSION