

This document is the property of Nian-Yeong Corporation and is delivered on the express condition that it is not to be disclosed, reproduced or used, in whole or in part, for manufacture or sale by anyone other than Nian-Yeong Corporation without its prior consent, and that no right is granted to disclose or to use any information in this document.

### CUSTOMER DRAWING

REV.	DESCRIPTION	APPROVED BY	DATE	ECN NO.
A	RELEASE	Emily Suen	05/08/11'	
B	CHANGE MATERIAL	Emily Suen	16/09/22'	
C				
D				

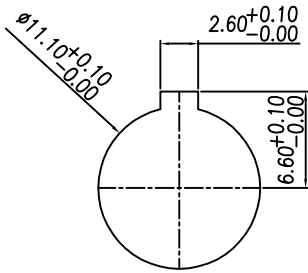

RECOMMENDED MOUNTING HOLE

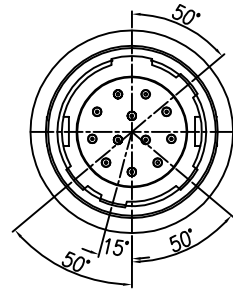

NUT

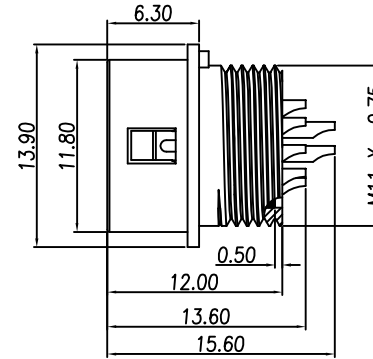

HOUSING+CONTACT+SPRING+SHELL

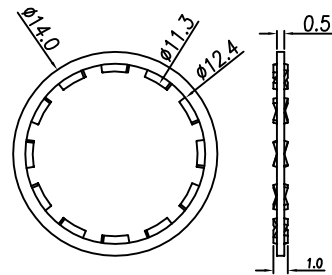
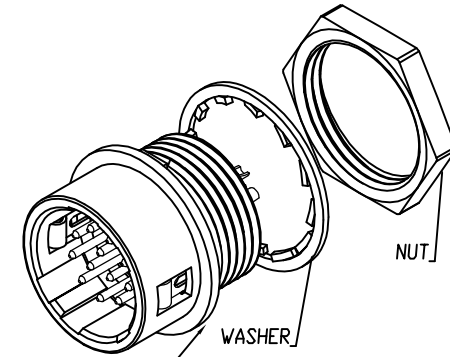

WASHER

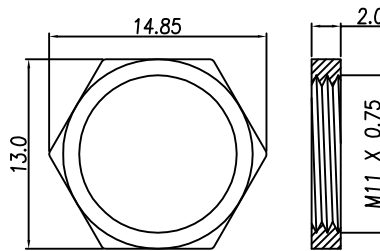

NUT

1. MATERIAL :

- 1-1. HOUSING : NYLON66 UL94V-0; COLOR : BLACK
- 1-2. CONTACT : BRASS
- 1-3. SHELL : ZINC ALLOY
- 1-4. SPRING : STAINLESS STEEL
- 1-5. WASHER : PHOSPHOR BRONZE
- 1-6. NUT : BRASS

3. ELECTRICAL SPECIFICATION :

- 3-1. Rated current : 2A
  - 3-2. Rated voltage : 100V AC / 140V DC
4. Environmental :
- 4-1. Operation Temperature : -25℃~85℃

2. FINISH :

- 2-1. CONTACT : GOLD FLASH
- 2-2. SHELL : NICKEL
- 2-3. WASHER : NICKEL
- 2-4. NUT : NICKEL

TABLE A

CONTACT ARRANGEMENT & DIMENSIONS(FRONT VIEW)	
DI-12M2-03	DI-10M2-03

DRAWN	Mark Kao	APPVL	Ku Chou	UNIT	mm	TOLERANCE		<b>NIAN YEONG ENTERPRISE</b> 年永實業有限公司	TITLE	DIN (M) 插座 (SHELL TYPE: RECEPTACLE)			SHEET
CHK'D	Emily Suen			SCALE	1:1	.x ±0.20 .xx ±0.10 .xxx ±0.05 .xxxx ±0.03 ANGULA ±1°			PART NO.	SEE TABLE A	DWG NO.	QC5556	VERSION