

This document is the property of Nian-Yeong Corporation and is delivered on the express condition that it is not to be disclosed, reproduced or used, in whole or in part, for manufacture or sale by anyone other than Nian-Yeong Corporation without its prior consent, and that no right is granted to disclose or to use any information in this document.

CUSTOMER DRAWING

REV.	DESCRIPTION	APPROVED BY	DATE	ECN NO.
A	RELEASE	Ku Chou	02/05/19*	
B				
C				

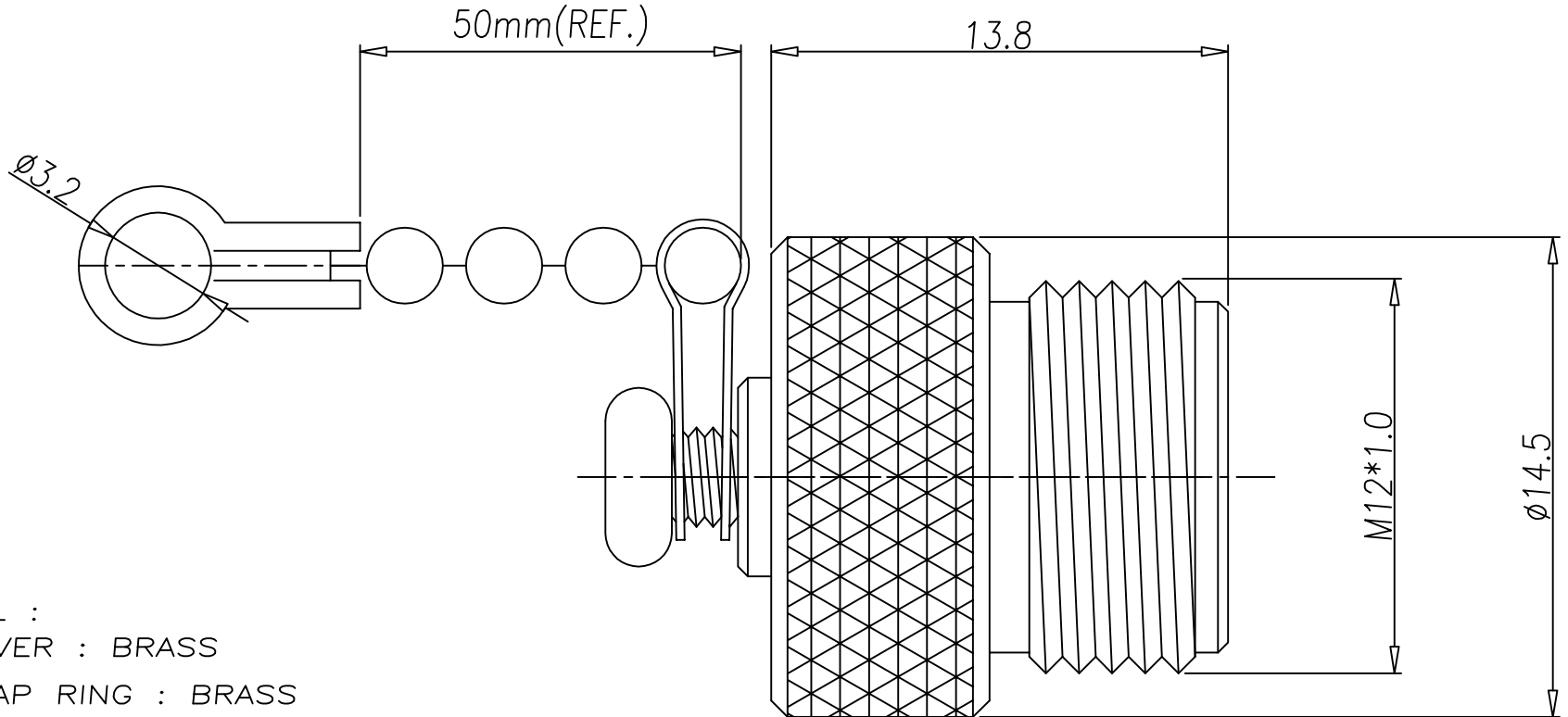

NOTE:

1. MATERIAL :

- 1-1. COVER : BRASS
- 1-2. SNAP RING : BRASS
- 1-3. SCREW : STEEL
- 1-4. BEAD CHAIN : STEEL

2. FINISH :

- 2-1. COVER : NICKEL PLATED OVER ALL
- 2-2. SCREW : NICKEL PLATED OVER ALL
- 2-3. SNAP RING : NICKEL PLATED OVER ALL

DRAWN	Ku Chou	APP'D	Emily Suen	UNIT	mm	TOLERANCE		TITLE	M12防塵蓋(外牙)+金屬鏈條(Ø3.2*50mm)+M3螺絲			SHEET	
CHK'D	Emily Suen			SCALE	1:1	.x ±0.20 .xx ±0.10 .xxx ±0.05 .xxxx ±0.03 ANGULA ±1°		PART NO.	NY-WP1451-10	DWG NO.	QC9103	VERSION	

NIAN YEONG ENTERPRISE
年永實業有限公司