

This document is the property of Nian-Yeong Corporation and is delivered on the express condition that it is not to be disclosed, reproduced or used, in whole or in part, for manufacture or sale by anyone other than Nian-Yeong Corporation without its prior consent, and that no right is granted to disclose or to use any information in this document.

CUSTOMER DRAWING

REV.	DESCRIPTION	APPVL. BY	DATE	ECN NO.
A	RELEASE	Fido Weng	24/02/09*	
B	RELEASE	Fido Weng	07/05/10*	
C				

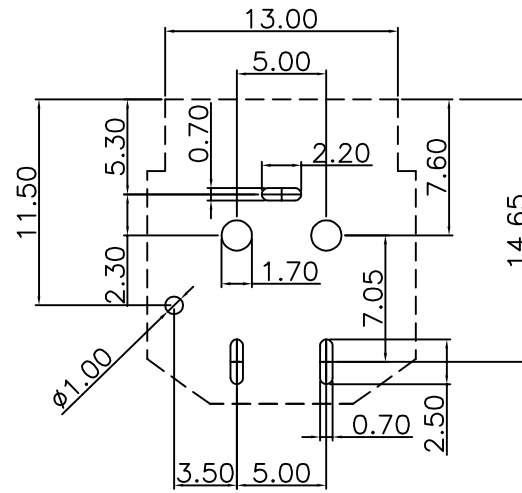
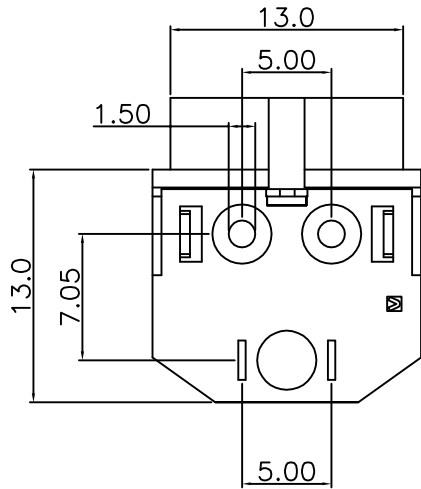
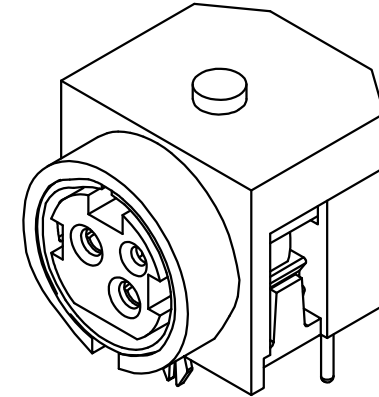
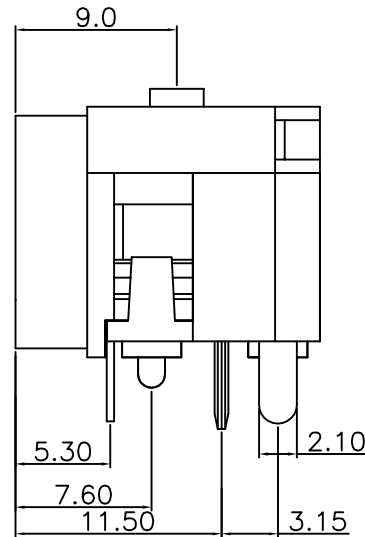
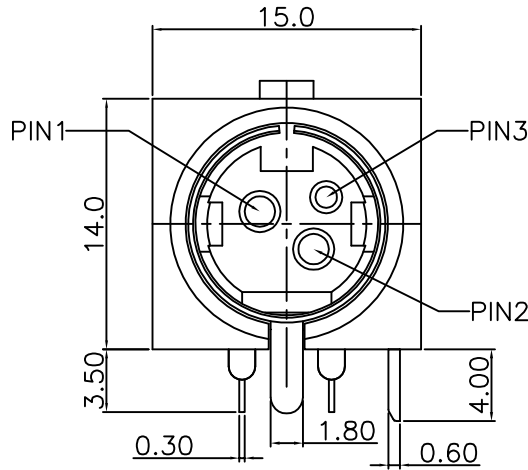

P.C.B LAYOUT(PART MOUNT SIDE)

- MATERIAL :
 - 1-1. HOUSING : PBT
 - 1-2. CONTACT : PHOSPHOR BRONZE
 - 1-3. GROUND : BRASS
 - 1-4. SHELL : SPCC
- FINISH :
 - 2-1. CONTACT : SILVER PLATING
 - 2-2. GROUND : NICKEL PLATED OVER ALL
- ELETRICAL SPECICATION :
 - 3-1. RATED CURRENT FOR 3P : PIN1&2 7.5A
PIN3 1A
RATED CURRENT FOR 4P : 7.5A FOR ALL PIN
 - 3-2. RATED VOLTAGE : 20V DC
 - 3-3. CONTACT RESISTANCE : 30mΩ
 - 3-4. INSULATION RESISTANCE : 50MΩ Min. at 250V DC
 - 3-5. DIELECTRIC STRENGTH : 250V AC / 1 minute
 - 3-6. INSERTION FORCE : 45N max.
 - 3-7. WITHDRAWAL FORCE : 9N TO 30N
 - 3-8. DURABILITY TEST : 1000 Cycles
- ENVIRONMENTAL :
 - 4-1. OPERATION TEMPERATURE : -20 °C~85°C

DRAW	Ren Liao	APPVL	Fido Weng	UNIT	mm	TOLERANCE	 NIAN YEONG ENTERPRISE 年永實業有限公司	TITLE	PowerDin 3(F) 板端圓形DIP (PBT)		SHEET	 VERSION A
CHECK	Emily Suen			SCALE	1:1	.x ±0.20 .xx ±0.15 .xxx ±0.10 .xxxx ±0.05 ANGULA ±1°		PART NO.	PD-03F3-01-01	DWG NO.	QC9484	