

This document is the property of Nian-Yeong Corporation and is delivered on the express condition that it is not to be disclosed, reproduced or used, in whole or in part, for manufacture or sale by anyone other than Nian-Yeong Corporation without its prior consent, and that no right is granted to disclose or to use any information in this document.

CUSTOMER DRAWING

REV.	DESCRIPTION	APPROVED BY	DATE	ECN NO.
A	RELEASE	Fido Weng	26/02/20*	
B				
C				

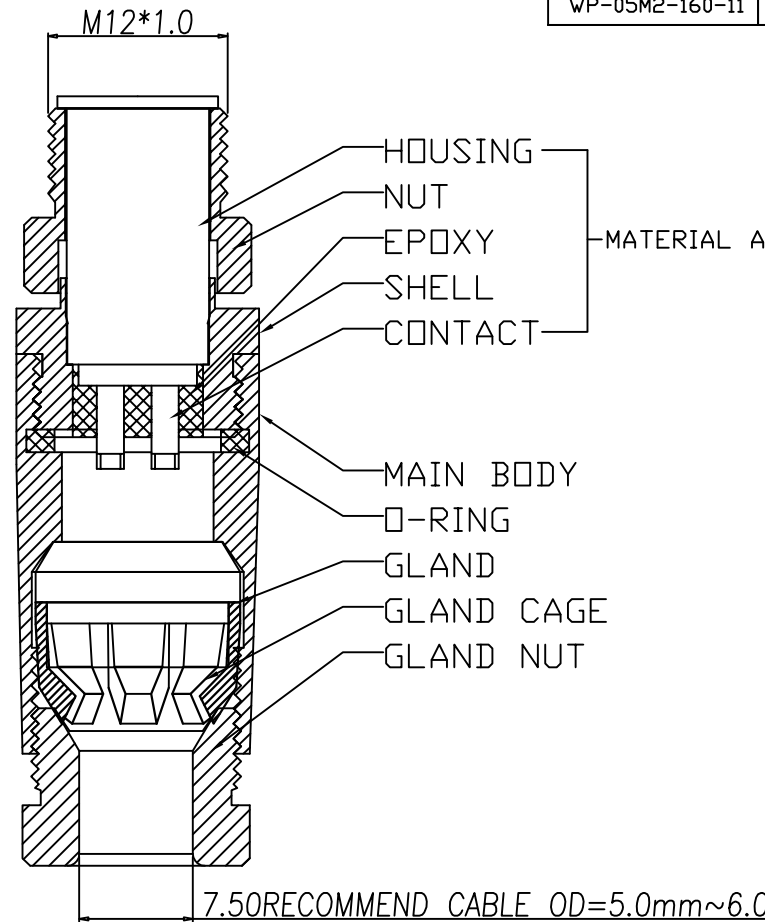
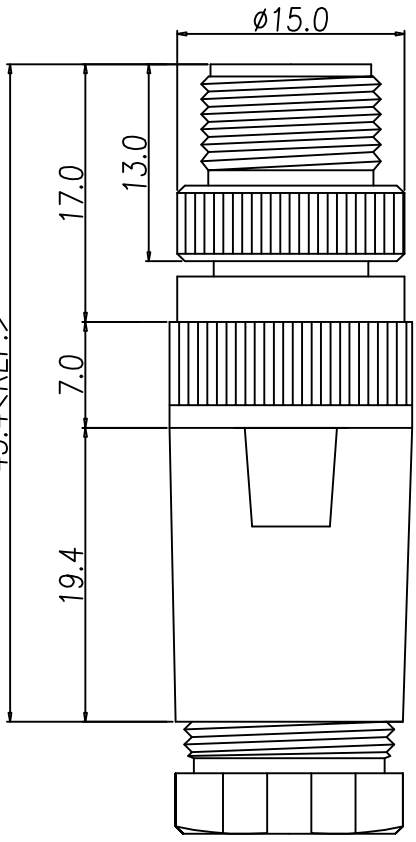
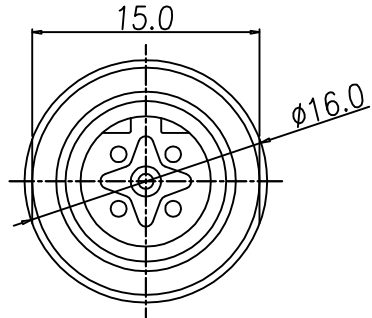

TABLE A

WP-05M2-160-11	WP-04M2-202-11	WP-03M2-115-11	WP-02M2-67-11

- MATERIAL :
  - MATERIAL A :
    - HOUSING : PBT UL94V-0 ; COLOR : BLACK.
    - CONTACT : BRASS
    - NUT : ALUMINIUM ALLOY
    - SHELL : ALUMINIUM ALLOY
  - MAIN BODY : ALUMINIUM ALLOY
  - GLAND : SILICONE COLOR : BLACK.
  - GLAND CAGE : POM ; COLOR : BLACK.
  - GLAND NUT : ALUMINIUM ALLOY
  - O-RING : SILICONE ; COLOR : BLACK.
- FINISH :
  - MATERIAL A :
    - CONTACT : GOLD FLASH MICRO INCHES MIN. UNDER PLATE : NICKEL.
    - NUT : SATIN NICKEL PLATED
    - SHELL : SATIN NICKEL PLATED
  - MAIN BODY : SATIN NICKEL PLATED
  - GLAND NUT : SATIN NICKEL PLATED.
- ELECTRICAL SPECIFICATION :
  - Rated current : 4A
  - Rated voltage : 2~4PIN 250V ; 5PIN 60V
  - Water proof : IP67/IP68
- Environmental :
  - Operation Temperature : -20℃~85℃

DRAWN	Ku Chou	APP'D	Emily Suen	UNIT	mm	TOLERANCE		<b>NIAN YEONG ENTERPRISE</b> 年永實業有限公司	TITLE	M12 (M) B-coded Assembly type			SHEET	
CHK'D	Emily Suen			SCALE	1:1	.x ±0.20 .xx ±0.10 .xxx ±0.05 .xxxx ±0.03 ANGULA ±1°			PART NO.	SEE TABLE A	DWG NO.	QC9582	VERSION	