

This document is the property of Nian-Yeong Corporation and is delivered on the express condition that it is not to be disclosed, reproduced or used, in whole or in part, for manufacture or sale by anyone other than Nian-Yeong Corporation without its prior consent, and that no right is granted to disclose or to use any information in this document.

CUSTOMER DRAWING

REV.	DESCRIPTION	APPROVED BY	DATE	ECN NO.
A	RELEASE	Ku Chou	08/01/19*	
B				
C				

TABLE A

P/N	MATERIAL(CLAMP RING)	CABLE OD ϕ
WP-03M2-111-11	PA66	ϕ 8.6mm~ ϕ 9.6mm
	PA66	ϕ 6.5mm~ ϕ 7.6mm
	PBT+PC, UL94V-0(F1)	ϕ 8.6mm~ ϕ 9.6mm
	PBT+PC, UL94V-0(F1)	ϕ 6.5mm~ ϕ 7.6mm

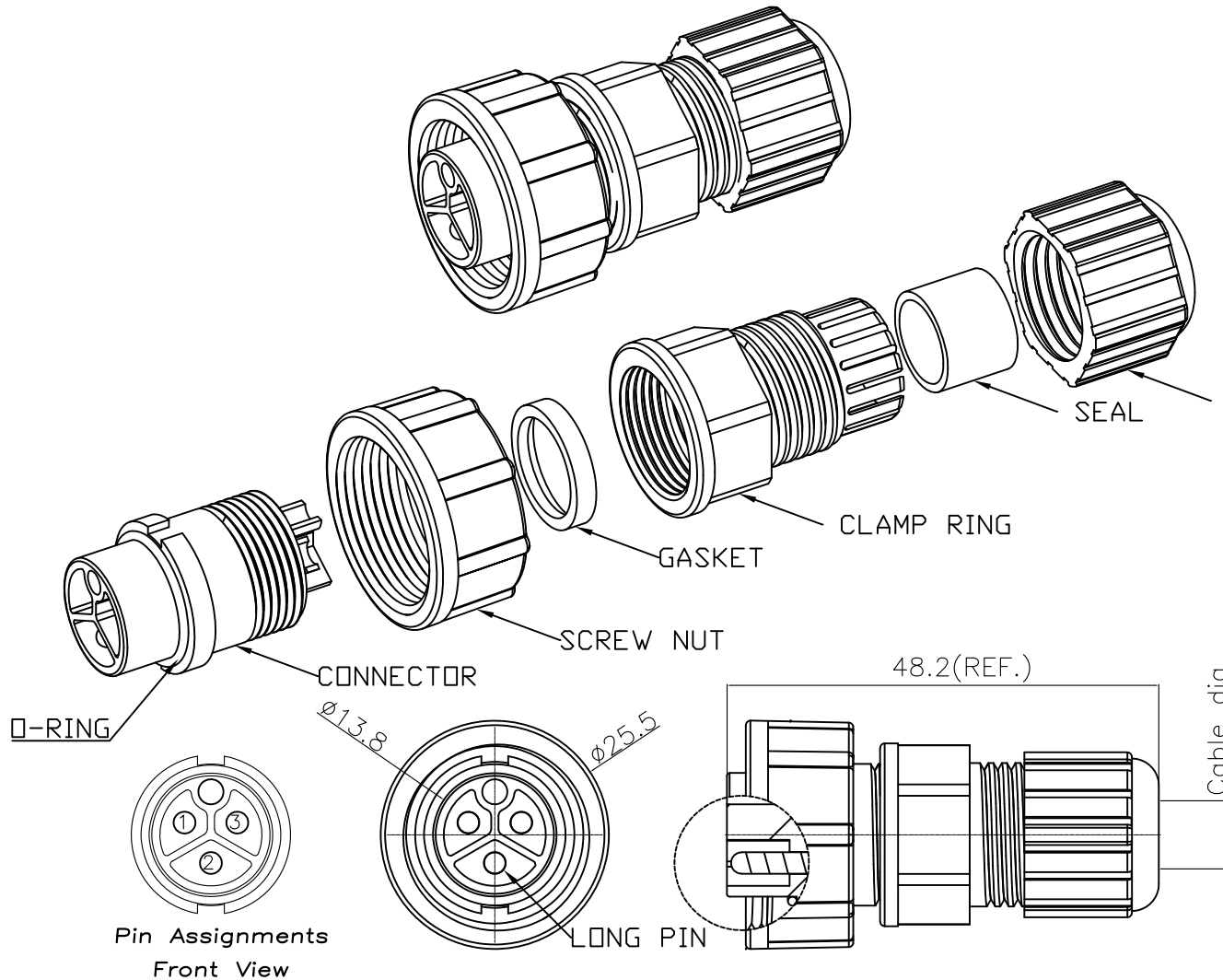

- MATERIAL :
 - HOUSING : PA66
 - CONTACT : BRASS
 - O-RING : SILICONE
 - SCREW NUT : PA66
 - GASKET : SILICONE
 - CLAMP RING : SEE TABLE A
 - SEAL : SILICONE
 - SEALING NUT : PA66
- FINISH :
 - CONTACT : GOLD FLASH PLATED.
- ELECTRICAL SPECIFICATION :
 - Rated current : 20A
 - Rated Voltage : 250V
 - Water proof : IP67
- Environmental :
 - Operation Temperature : -40 $^{\circ}$ C~105 $^{\circ}$ C

DRAW	Emily Suen	APP'D	Ku Chou	UNIT	mm	TOLERANCE		NIAN YEONG ENTERPRISE 年永實業有限公司	TITLE	WP 3P FEMALE (MALE PIN) C SIZE ASSEMBLY TYPE(SCREW)			SHEET	A
CHECK	Ku Chou			SCALE	1:1	.x \pm 0.20 .xx \pm 0.10 .xxx \pm 0.05 .xxxx \pm 0.03 ANGULAR \pm 1 $^{\circ}$			PART NO.	SEE TABLE A	DWG NO.	QC9142	VERSION	