

This document is the property of Nian-Yeong Corporation and is delivered on the express condition that it is not to be disclosed, reproduced or used, in whole or in part, for manufacture or sale by anyone other than Nian-Yeong Corporation without its prior consent, and that no right is granted to disclose or to use any information in this document.

# CUSTOMER DRAWING

REV.	DESCRIPTION	APPROVED BY	DATE	ECN NO.
A	RELEASE	Ku Chou	11/03/19*	
B				
C				

TABLE A

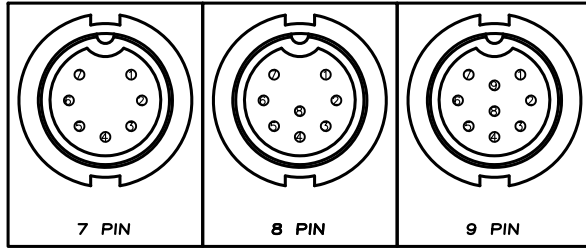

Pin Assignments  
Front View

TABLE A

P/N	MATERIAL(CLAMP RING)
WP-09M2-16-11	PBT+PC, UL94V-0(F1)
WP-09M2-15-11	PA66
WP-08M2-83-11	PA66
WP-07M2-14-11	PA66

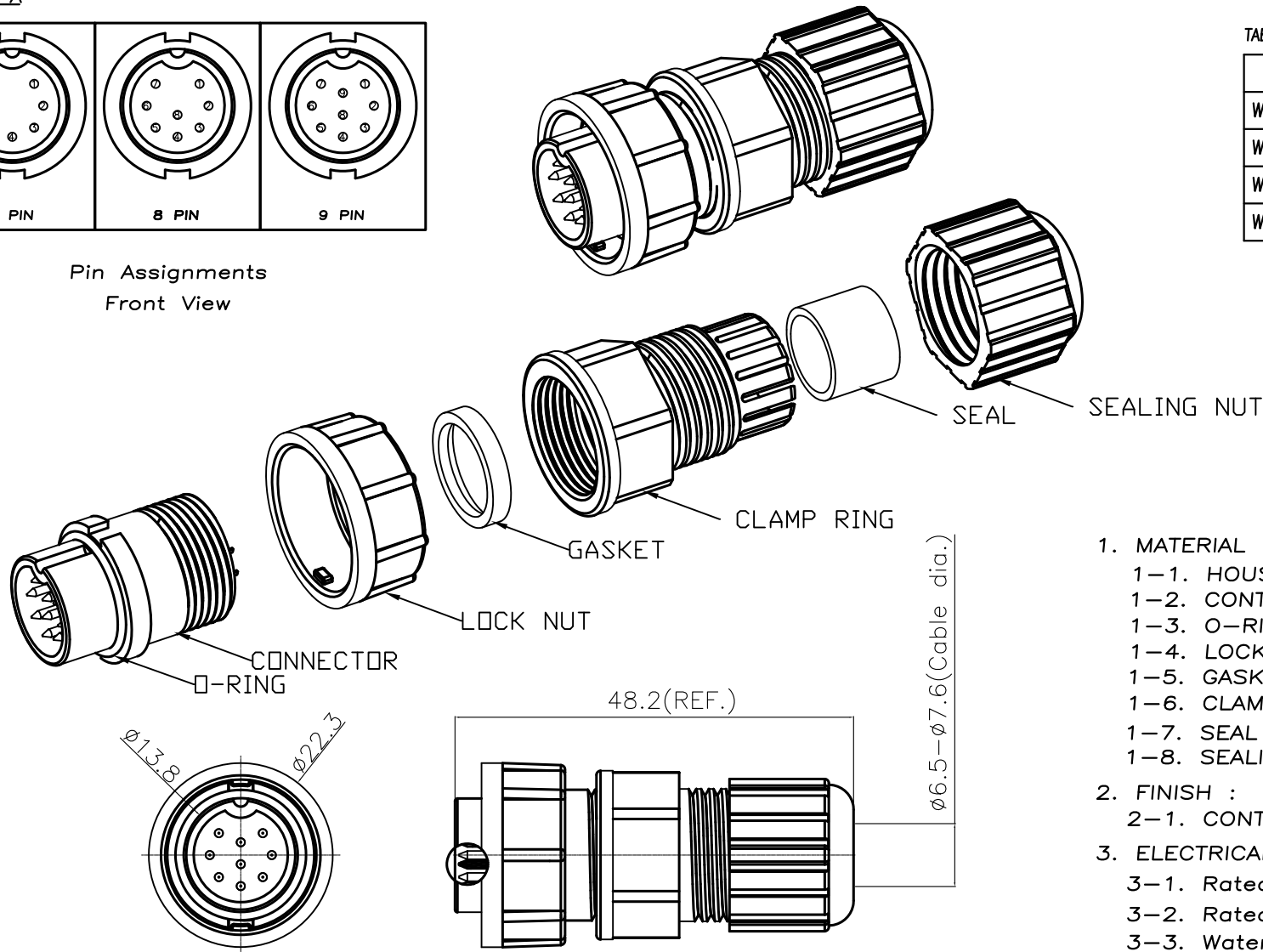

- MATERIAL :
  - HOUSING : PA66
  - CONTACT : BRASS
  - O-RING : SILICONE
  - LOCK NUT : PA66
  - GASKET : SILICONE
  - CLAMP RING : SEE TABLE A
  - SEAL : SILICONE
  - SEALING NUT : PA66
- FINISH :
  - CONTACT : GOLD FLASH PLATED.
- ELECTRICAL SPECIFICATION :
  - Rated current : 5A
  - Rated Voltage : 250V
  - Water proof : IP67
- Environmental :
  - Operation Temperature : -40°C~105°C

DRAW	Emily Suen	APP'D	Ku Chou	UNIT	mm	TOLERANCE	 NIAN YEONG ENTERPRISE 年永實業有限公司	TITLE	WP C SIZE F CONN (M PIN) ASSEMBLY TYPE(LOCK)			SHEET
CHECK	Ku Chou			SCALE	1:1	.x ±0.20 .xx ±0.10 .xxx ±0.05 .xxxx ±0.03 ANGULAR ±1°		PART NO.	SEE TABLE A	DWG NO.	QC8975	VERSION