

This document is the property of Nian-Yeong Corporation and is delivered on the express condition that it is not to be disclosed, reproduced or used, in whole or in part, for manufacture or sale by anyone other than Nian-Yeong Corporation without its prior consent, and that no right is granted to disclose or to use any information in this document.

CUSTOMER DRAWING

REV.	DESCRIPTION	APPROVED BY	DATE	ECN NO.
A	RELEASE	Ku Chou	20/07/18'	
B	CHANGE CLAMP RING MATERIAL	Ku Chou	31/10/18'	
C				

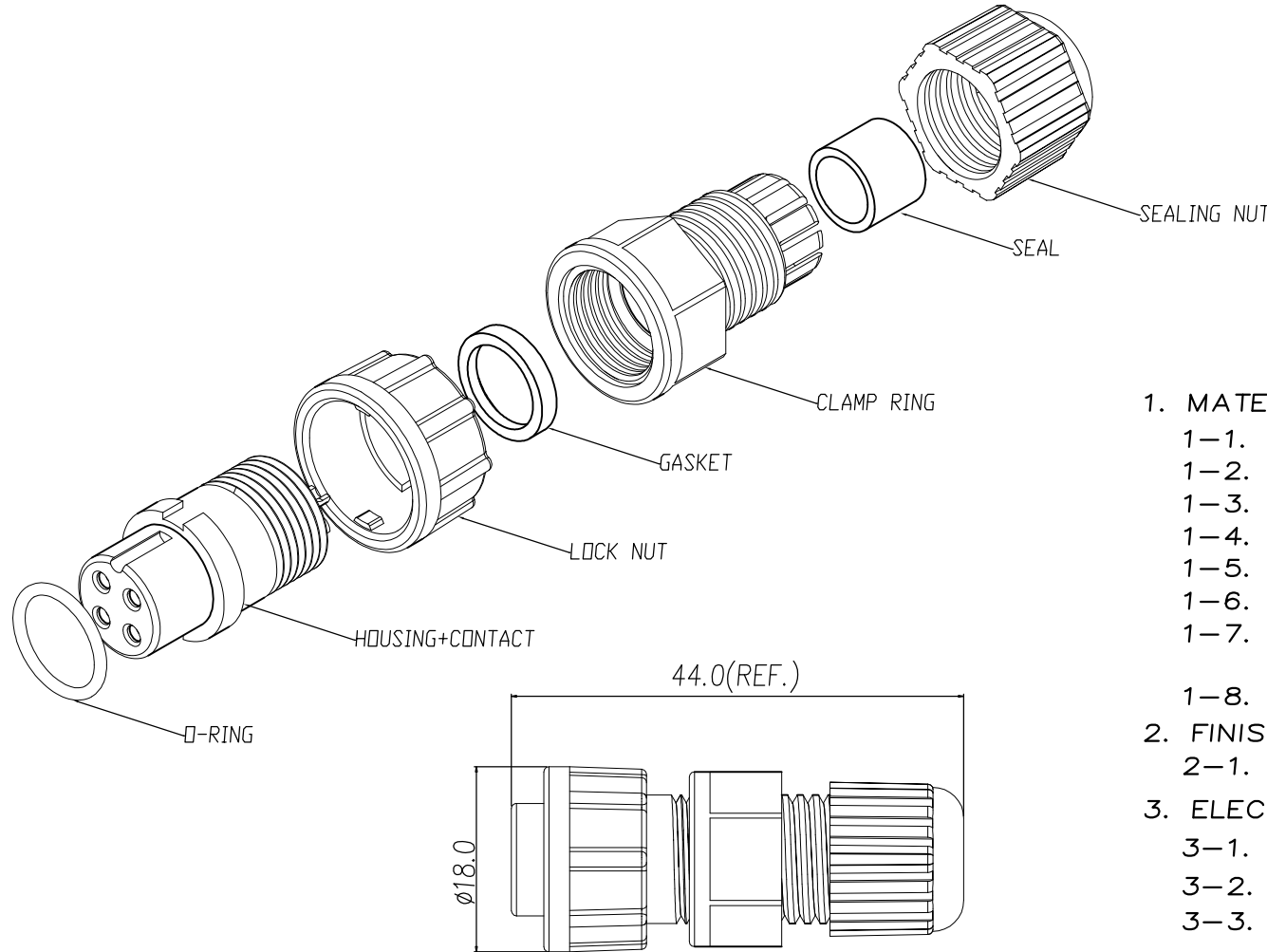

TABLE A

2 PIN	3 PIN	4 PIN
WP-02F2-54-11	WP-03F2-96-11	WP-04F2-194-11

PIN ASSIGNMENTS
FRONT VIEW

- MATERIAL :
 - 1-1. HOUSING : PA66
 - 1-2. CONTACT : BRASS
 - 1-3. O-RING : SILICONE
 - 1-4. LOCK NUT : PA66
 - 1-5. GASKET : SILICONE
 - 1-6. CLAMP RING : PA66 Δ
 - 1-7. SEAL : SILICONE
CABLE OD ϕ 4.5mm ~6.5mm
 - 1-8. SEALING NUT : PA66
- FINISH :
 - 2-1. CONTACT : GOLD FLASH PLATED.
- ELECTRICAL SPECIFICATION :
 - 3-1. Rated current : 10A
 - 3-2. Rated voltage : 250V
 - 3-3. Water proof : IP67
- Environmental :
 - 4-1. Operation Temperature : -40 $^{\circ}$ C~105 $^{\circ}$ C

DRAWN	Emily Suen	APP'D	Ku Chou	UNIT	mm	TOLERANCE			TITLE	WP (F) (LOCK) B SIZE ASSEMBLY TYPE(10A)			SHEET
CHK'D	Ku Chou			SCALE	1:1	.x ± 0.20 .xx ± 0.10 .xxx ± 0.05 .xxxx ± 0.03 ANGULA $\pm 1^{\circ}$			PART NO.	SEE TABLE A	DWG NO.	QC8634	VERSION B

NIAN YEONG ENTERPRISE
年永實業有限公司