

This document is the property of Nian-Yeong Corporation and is delivered on the express condition that it is not to be disclosed, reproduced or used, in whole or in part, for manufacture or sale by anyone other than Nian-Yeong Corporation without its prior consent, and that no right is granted to disclose or to use any information in this document.

CUSTOMER DRAWING

REV.	DESCRIPTION	APPROVED BY	DATE	ECN NO.
A	RELEASE		04/03/13*	
B	統一電鍍規格		08/04/13*	

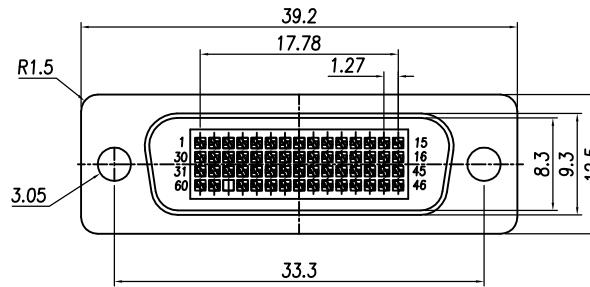
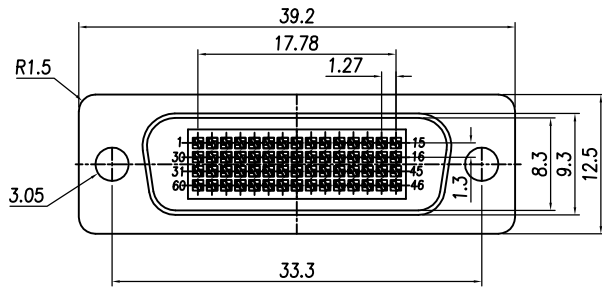
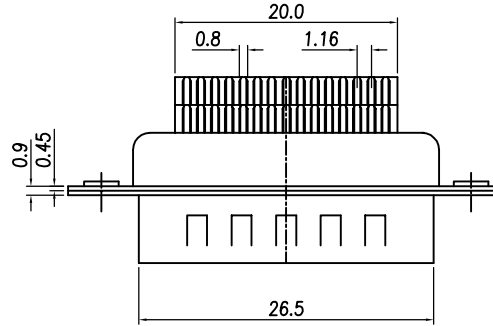
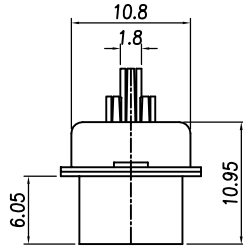

LFH-60M1-01/LFH-60M1-03

LFH-60M1-02/LFH-60M1-04

備註 / NOTE:

1. 安規 / SAFETY:
 - 1-1. 額定電流 / RATING CURRENT: 1A
 - 1-2. 額定電壓 / RATING VOLTAGE: 40V AC
 - 1-3. 絕緣阻抗 / INSULATION RESISTANCE: 100Mohms MIN at 500V DC for 1 MINUTE
 - 1-4. 絕緣耐壓 / WITHSTANDING: 500V AC for 1 MINUTE
2. 材質 / MATERIAL:
 - 2-1. 膠芯 : LCP
 - 2-2. 端子 / PIN: 磷銅 / PHOSPHOR BRONZE / PBT
 - 2-3. 鐵殼 / SHELL: 鐵 / IRON 0.4m/m
3. 電鍍 / PLATING: 端子 / PIN: SEE TABLE A

TABLE A

LFH-60M1-02	LFH 60(M)成型式(特殊)	金 10u"/GL0D10u", 錫 80u"~ 120u"/TIN80u"~ 120u"
LFH-60M1-04	LFH 60(M)成型式(特殊)	金 30u"/GL0D30u", 錫 80u"~ 120u"/TIN80u"~ 120u"
LFH-60M1-01	LFH 60(M)成型式	金 10u"/GL0D10u", 錫 80u"~ 120u"/TIN80u"~ 120u"
LFH-60M1-03	LFH 60(M)成型式	金 30u"/GL0D30u", 錫 80u"~ 120u"/TIN80u"~ 120u"
P/N	DESCRIPTION	PLATING

DRAWN	Mark Kao	APP'D	Ku Chou	UNIT	mm	TOLERANCE			TITLE	LFH 60(M)成型式			SHEET	
CHK'D	Emily Suen			SCALE	1:1	.x ±0.10 .xx ±0.05 .xxx ±0.03 .xxxx ±0.01 ANGULA ±1°			PART NO.	SEE TABLE A	DWG NO.	QC0555	VERSION	